

Jacobsen Declaration Exhibit O

Instructions for DH121 Series Decoder Installation DH121, DH121P, DH121PS, DH121AT



450 Cemetery ST #206 Norcross, GA USA 30071
(770)441-7992 FAX (770)441-0759
Web Site: <http://www.digitrax.com>

Digitrax Command Control

DH121 **1.5 Amp Digital Command Control Decoder**

1.5 Amp (2.0 Amp Peak) Mobile DCC Decoder

Easy connect decoder wire harness

Supports Both Short (127) & Long (10,000) Address Modes

User Programmable Address, Acceleration, Deceleration,
Start-voltage, Mid-point voltage, Max Voltage and more

Programmable from DCC compatible equipment without opening the loco

Smooth conversion to analog operation with functions operational

2 User Configurable, Independent Function Leads Rated at 200ma
Can be used as independent functions or directional headlights

Smooth locomotive speed control with user selectable
14, 28, or 128 forward & reverse speed step capabilities

User loadable speed tables for customized speed control

Supports Basic, Advanced & UniVersal Consisting

Compatible with the NMRA DCC Standard

Complies with FCC Part 15, class B RFI requirements

Made in USA





Decoder Installation Wiring Diagram For DH121 Series Decoders

See Digitrax Decoder Users Manual for complete decoder test procedures, installation instructions & technical information. This manual is available at no charge from your dealer. If your dealer is out of these manuals, contact Digitrax (770) 441-7992, Fax (770) 441-0759, or e-mail sales@digitrax.com and we will gladly send you a copy.

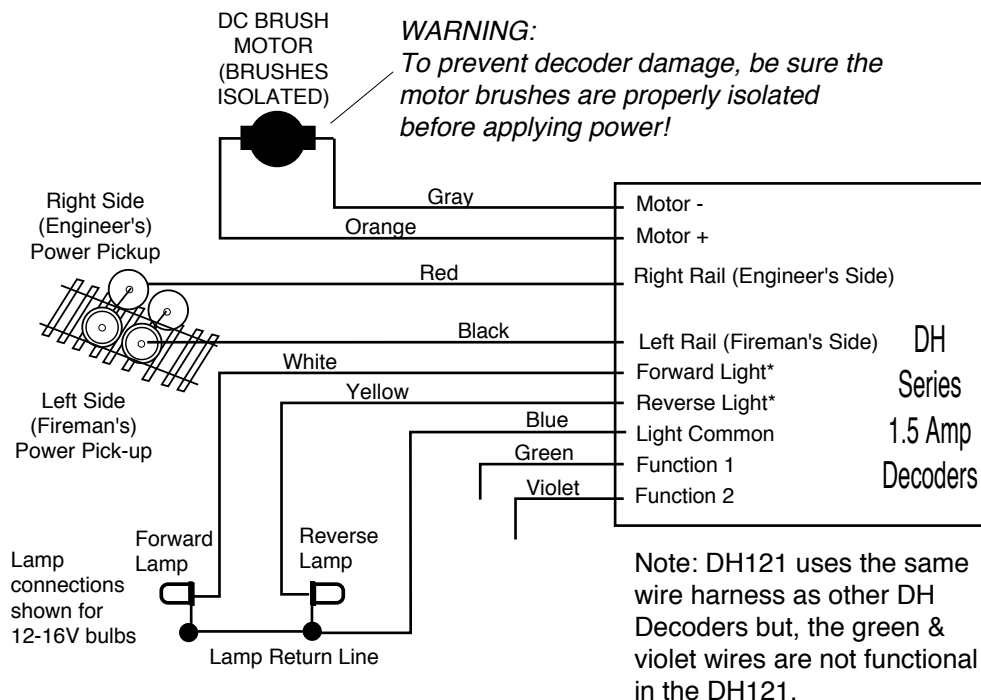

* On DH142 & DH121, forward and reverse lights can be run as independent functions on F0 & F4. See CV61 below and see Digitrax Decoder Manual for Complete Instructions.

Commonly Used Configuration Variables			Commonly Used Configuration Variables		
CV#	Used For	Default	CV#	Used For	Value
CV01	2-digit address	03	CV61	Directional Lights or	0
CV02	Start Voltage	0		White=F0 & Yellow=F4.	1
CV03	Acceleration Rate	0	CV49-54	FX Effect Set ups	See Manual
CV04	Deceleration Rate	0	CV65-95	Loadable Speed	See Manual
CV05	Maximum Voltage	0		Tables	
CV06	Mid Point Voltage	0			
CV29	Configuration Register	06=Advanced Mode, Analog Conversion On			
	Examples:	04=Standard Mode (14 Speed Steps), Analog Conversion On			
		07=Reversed Direction, Advanced Mode, Analog Conversion On			
		16=Enable Loadable Speed Table, Analog Conversion On			

Damaged decoders should be returned directly to Digitrax for repair. The standard repair charge is \$17.